

**ZD1 Zoning Diagram**  
Must be typewritten.

Orient and affix BIS  
job number label here

Submitted to resolve objections stated in a notice of intent to revoke issued pursuant to rule 101-15.  Yes  No

**Location Information**

House No(s) 70-28  
Street Name GRAND CENTRAL PARKW  
Borough Queens  
Block 2248  
Lot 230  
BIN 4566457

Falsification of any statement is a misdemeanor and is punishable by a fine or imprisonment, or both. It is unlawful to give to a city employee, or for a city employee to accept, any benefit, monetary or otherwise, either as a gratuity for properly performing the job or in exchange for special consideration. Violation is punishable by imprisonment or fine or both. I understand that if I am found after hearing to have knowingly or negligently falsified or allowed to be falsified any certificate, form, signed statement, application, report or certification of the correction of a violation required under the provisions of this code or of a rule of any agency, I may be barred from filing further applications or documents with the Department.

Name (please print) LUIGI RUSSO 06/12/2024  
Date

Signature \_\_\_\_\_ Date

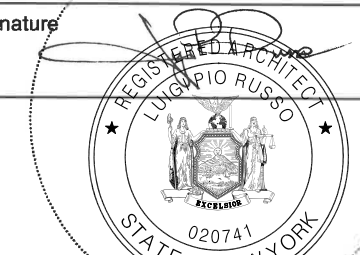

P.E. / R.A. Seal (apply seal, then sign and date over seal)

**Internal Use Only**

BIS Doc # \_\_\_\_\_

PLAN EXAMINER SIGN AND DATE

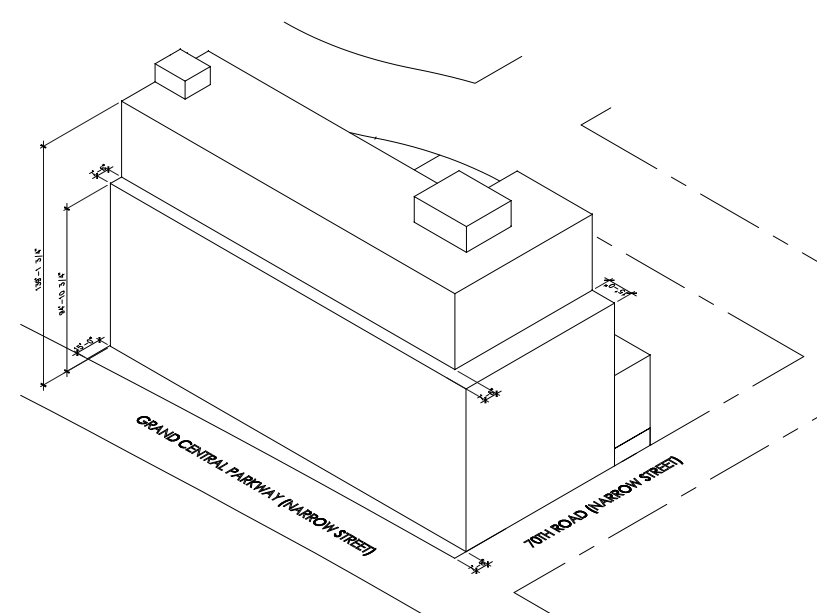
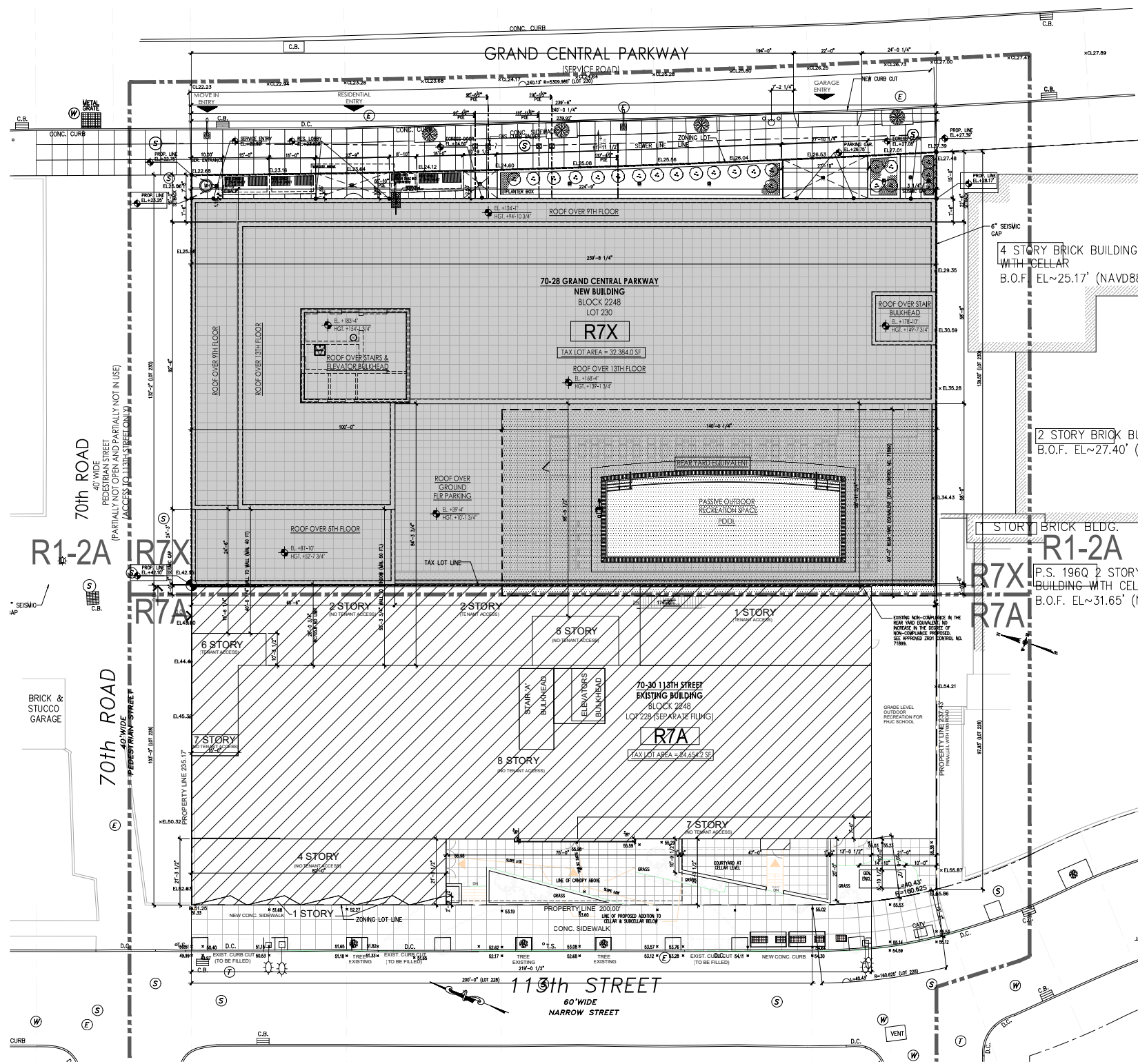

REQUIRED SETBACKS:  
FRONT: AS PER ZR 23-662(c)  
REAR: AS PER ZR 23-47, 23-541 & 23-533  
SIDE: AS PER 23-23(c)

