



ZD1 Zoning Diagram
Must be typewritten.

Orient and affix BIS job number label here

Submitted to resolve objections stated in a notice of intent to revoke issued pursuant to rule 101-15.

Yes No

Location Information

House No(s) 1487
Street Name 1ST AVENUE

Borough MANHATTAN
Block 1452
Lot 27, 24, 26, 123, 124
BIN 1045212

Falsification of any statement is a misdemeanor and is punishable by a fine or imprisonment, or both. It is unlawful to give to a city employee, or for a city employee to accept, any benefit, monetary or otherwise, either as a gratuity for properly performing the job or in exchange for special consideration. Violation is punishable by imprisonment or fine or both. I understand that if I am found after hearing to have knowingly or negligently falsified or allowed to be falsified any certificate, form, signed statement, application, report or certification of the correction of a violation required under the provisions of this code or of a rule of any agency, I may be barred from filing further applications or documents with the Department.

Name (please print)

DAVID WEST

Signature

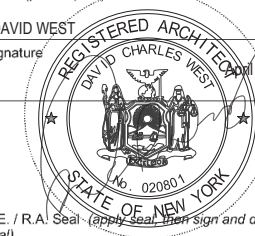

Date
April 12, 2022

P.E. / R.A. Seal (affix seal here sign and date over seal)

Internal Use Only

BIS Doc #

PLAN EXAMINER SIGN AND DATE

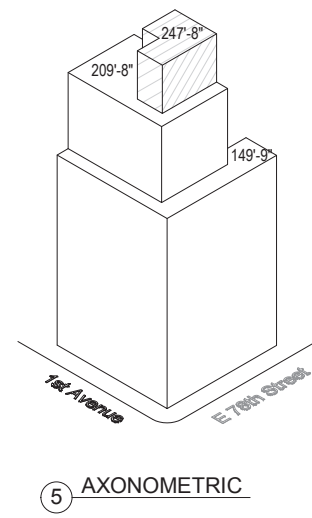
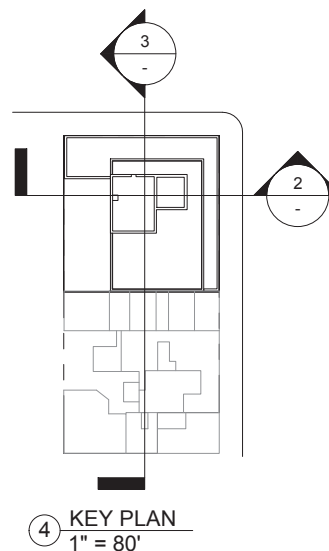
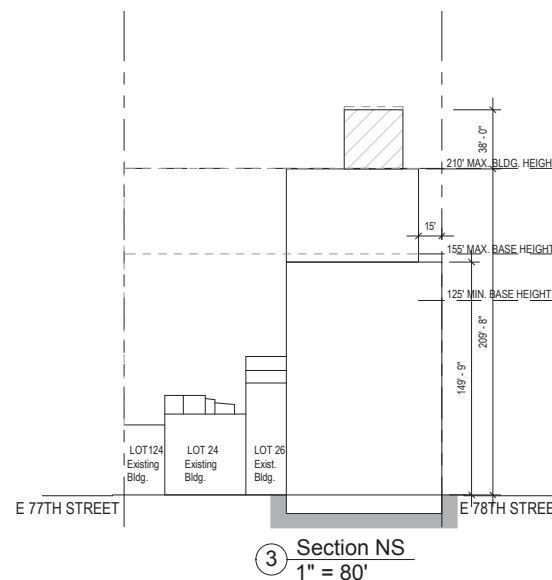
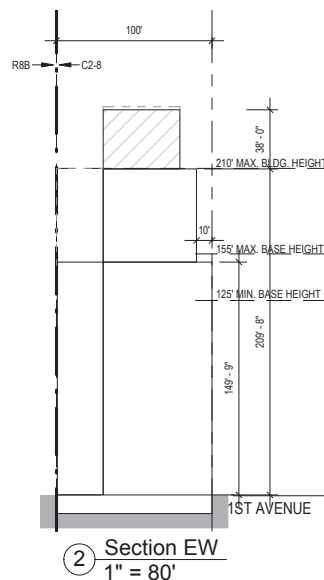
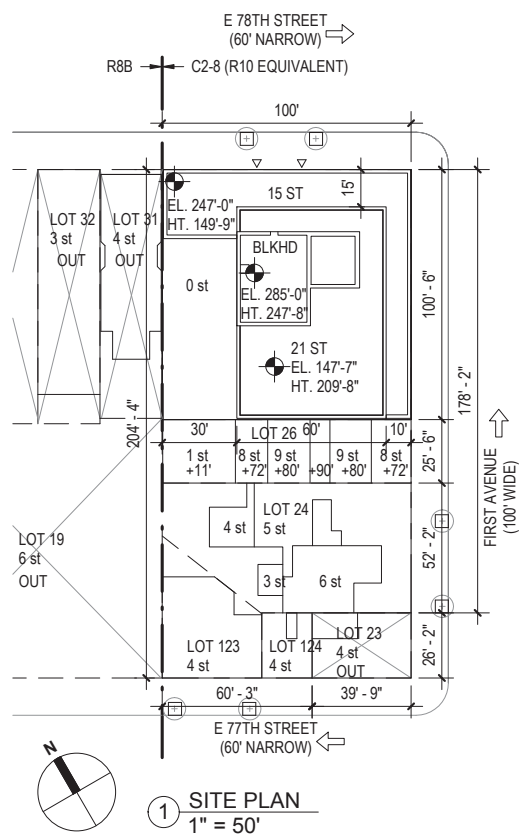

LEGEND

- PROPOSED BUILDING
- ZONING LOT LINE
- DISTRICT BOUNDARY
- MAXIMUM BUILDING ENVELOPE
- PERMITTED OBSTRUCTION
- STREET TREE

C2-8 (R10 EQUIVALENT)
LOT AREA: 19,393 sf
BUILDING HEIGHT PER ZR 23-662
STREET WALL LOCATION PER ZR 35-651(b)

